

# Appetizer

## Tidlig Kvalitetssikring af Planer



Risk Management & Estimering i én proces. [Mail@compilot.dk](mailto:Mail@compilot.dk) for slides



## Hvad ønsker vi at opnå?

1. **At identificere og estimere usikkerheder** - for at kvalitetssikre projektet
2. **At identificere en vidde for projektets varighed** - for at vælge robusthed
3. **At få et fælles billede af projektet** - for at opnå ejerskab & motivation
4. **At lave handlingsplaner** - for at udnytte muligheder og reducere risici



# Processen - Varighed

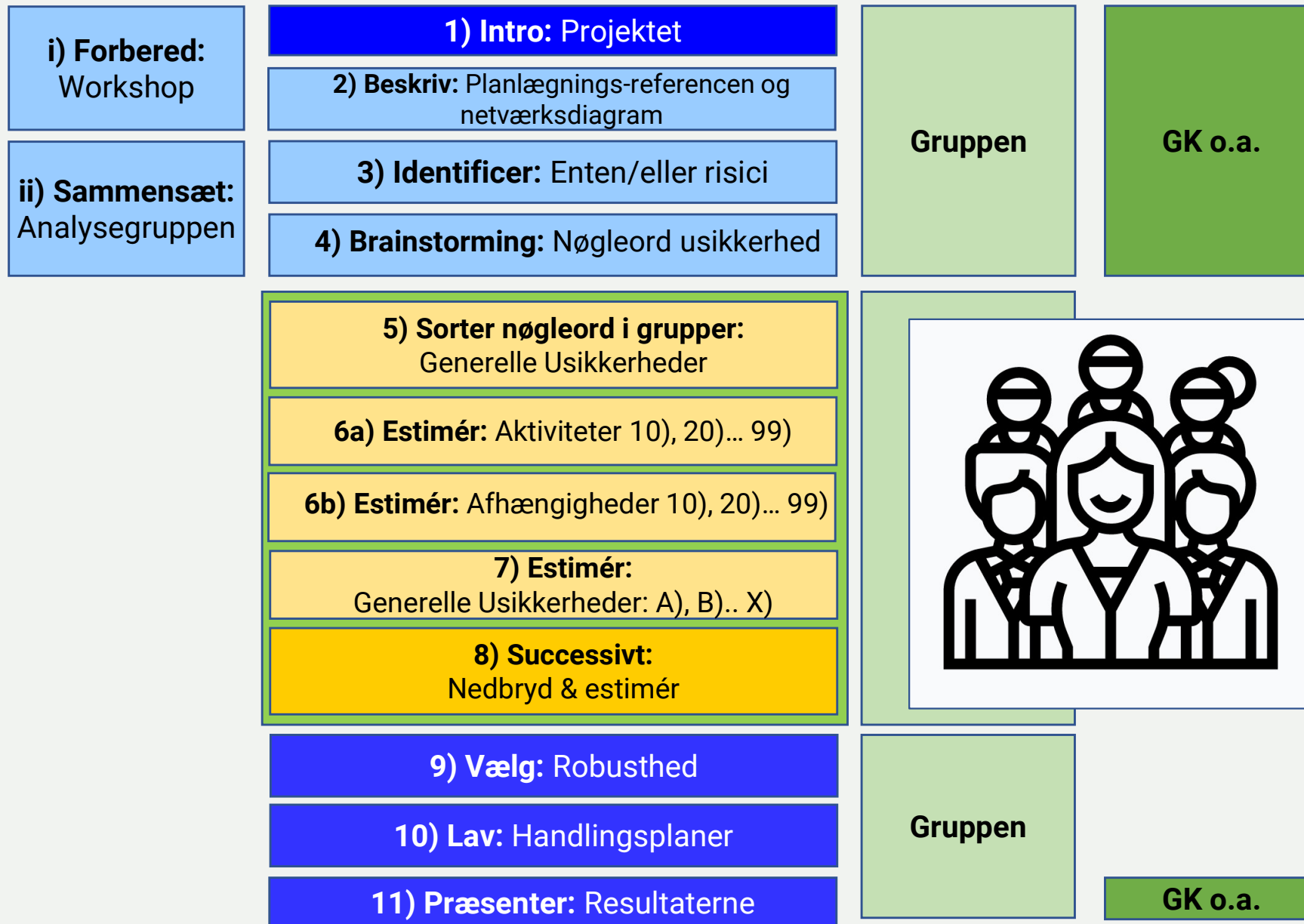

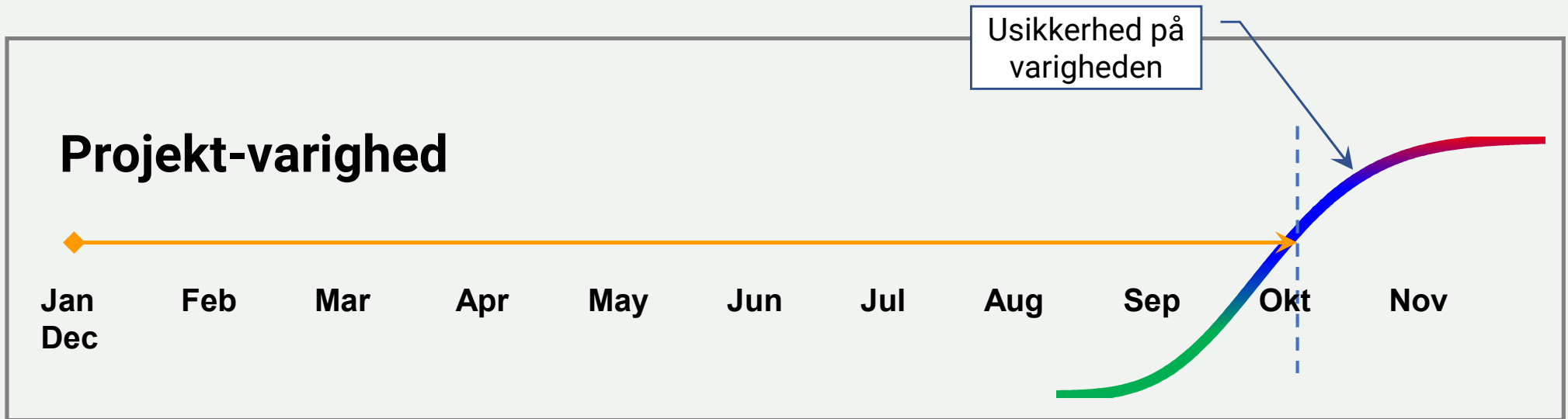

## Handlingsplan

#	Handling	Bet. (1-3-5)	Hvem	Hvornår
1.	Sikre mandat i	5	HKS	u05'23
2.	Få sparring mht design	3	JKS	u02'23
3.	Definere kontraktstrategi	5	EPJ	u03'23
4.	Ansæt en Teambuilding leder	5	HLS	u02'23
5.	Involver 1-2 entreprenører i predesign	3	POL	u06'23
..				
..				
..				
xx.	Sikre en forsikringsplan	1		u10'23

## Top10 usikkerheder

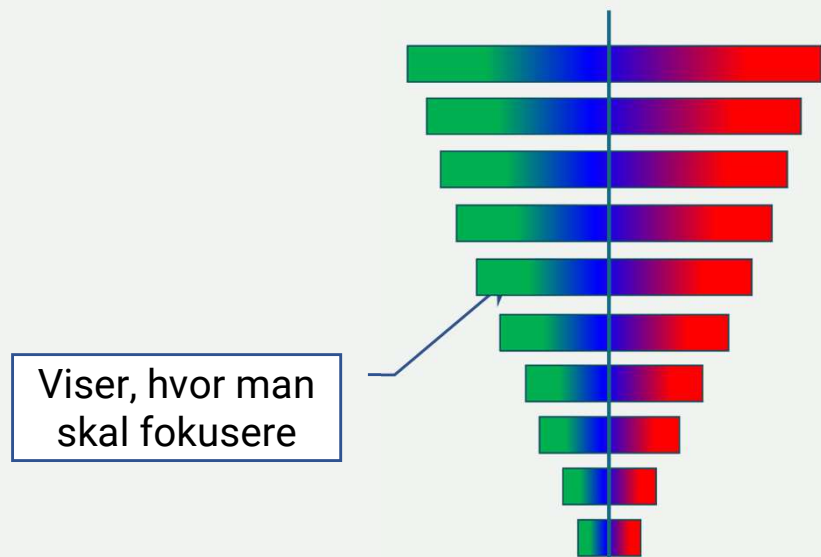



# Development Project

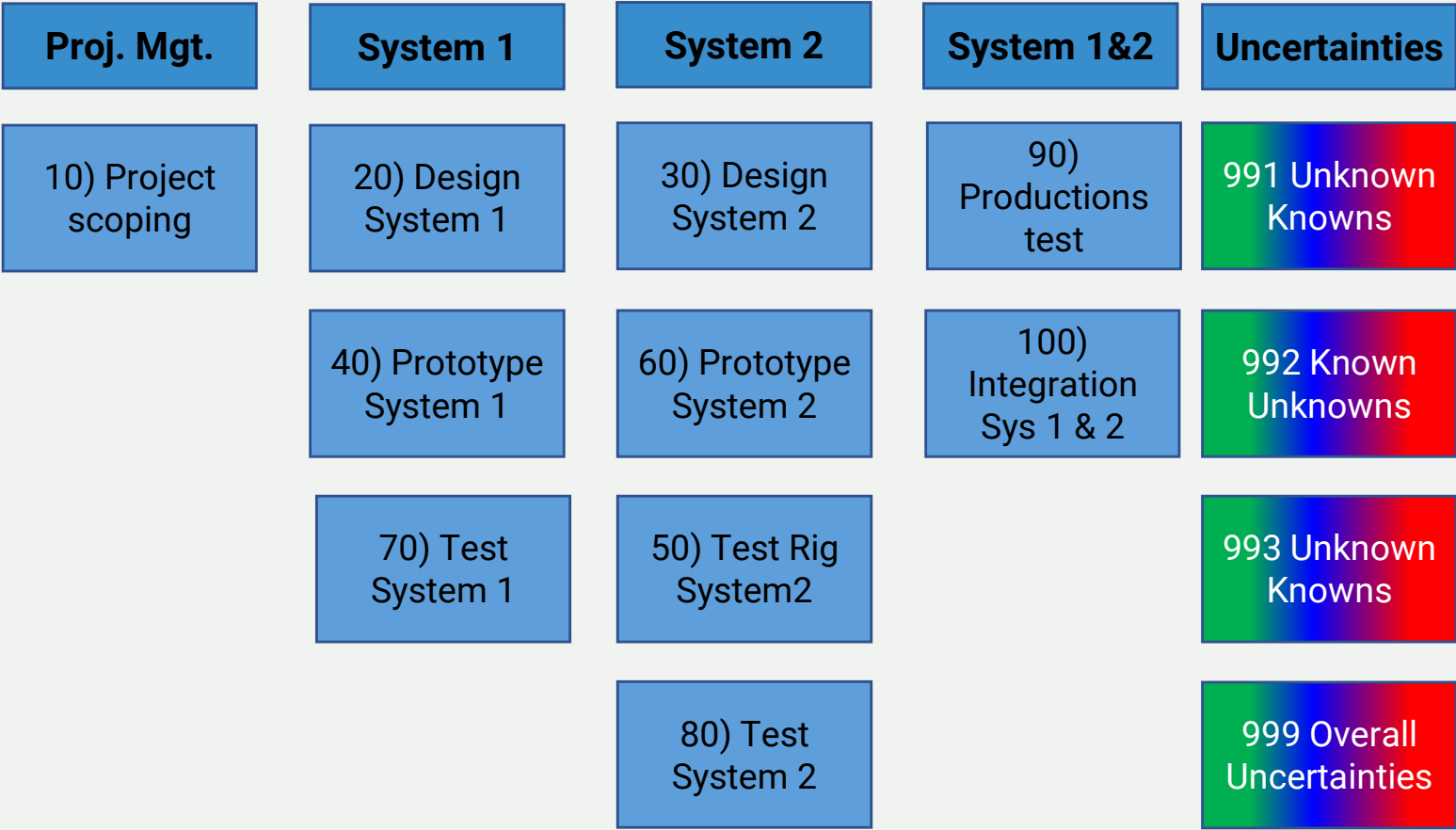

# Estimering af varigheder



**Loop 1a**  
Estimering af aktiviteter.

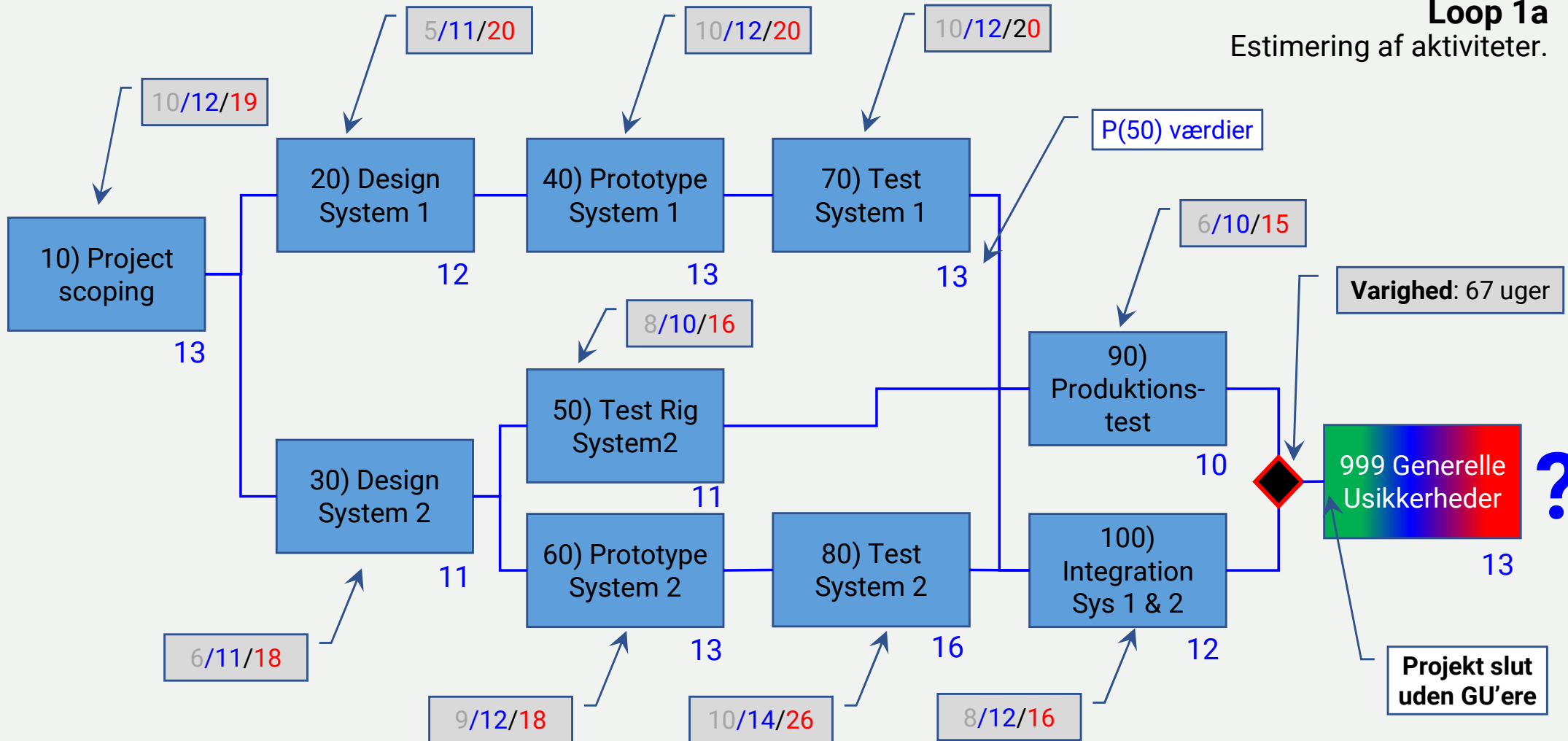



## Kompression of varigheden

**Loop 1b:**  
Estimering af afhængighederne.

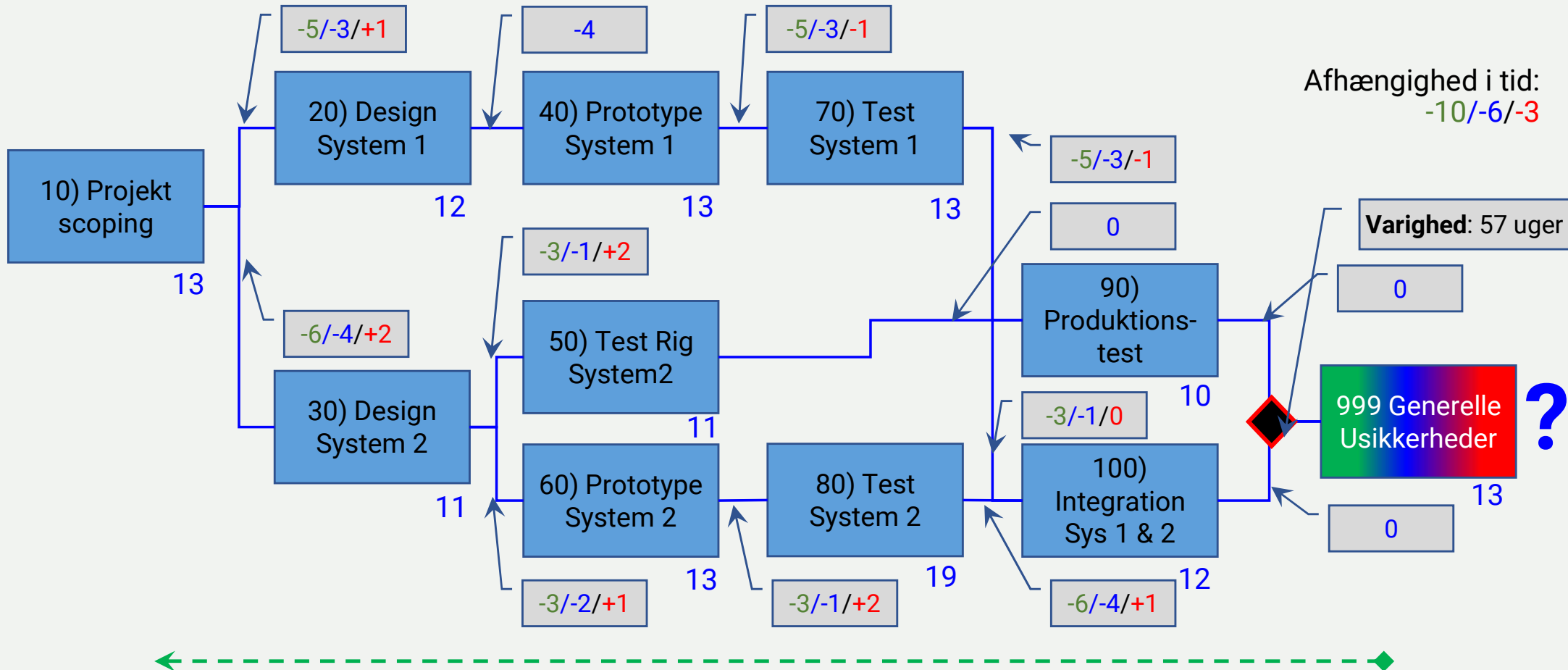

P(50) værdier uden OF'ere

Overlap (fremskyndelse) estimeres bagfra  
Overlap: Tidlig start eller sen start



# Projektvarighed Loop 2



# Nedbrydning af Top1 aktiviteten



**Loop 2**  
En kritisk aktivitet nedbrydes

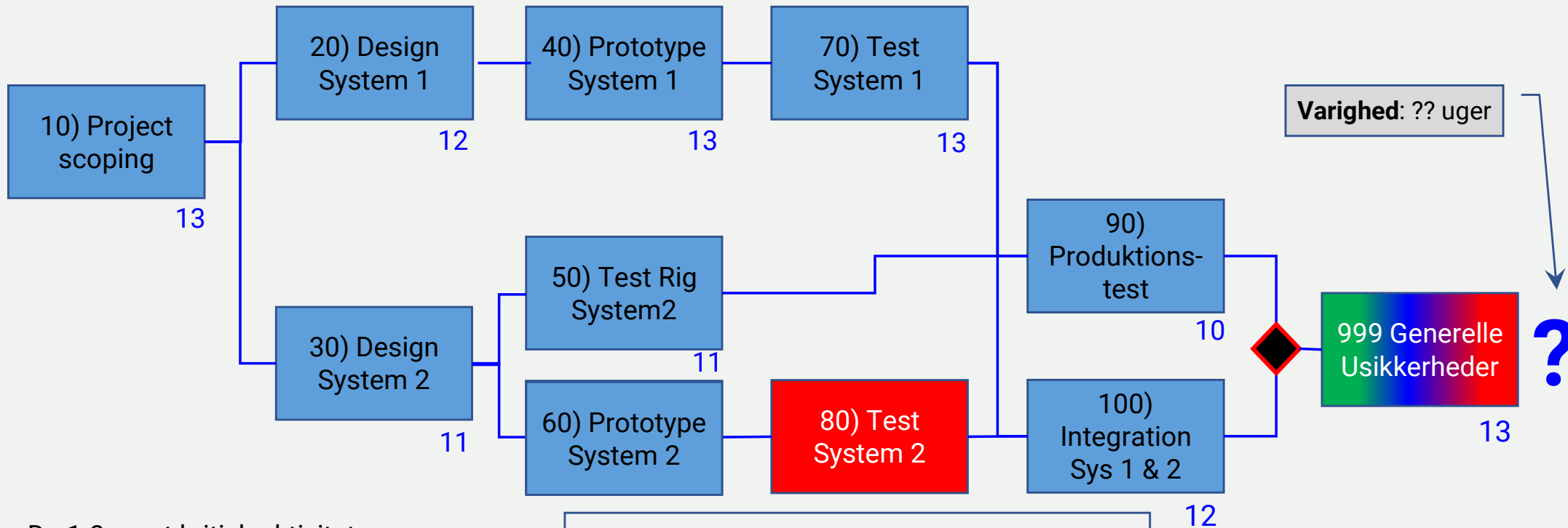

De 1-3 mest kritisk aktiviteter nedbrydes til næste niveau for at komme tættere på usikkerhederne.  
(Her kun Top1)

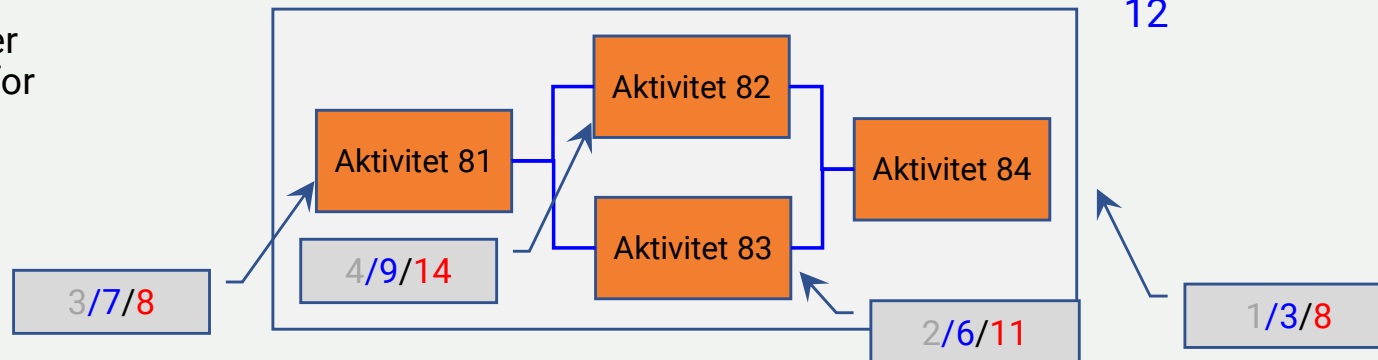

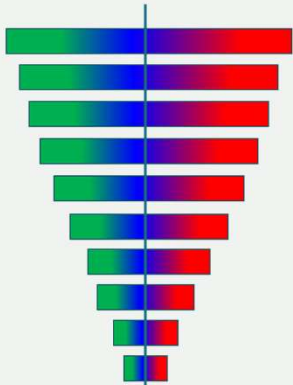

## Top5 usikkerheder:

- 1) Usikkerheden af selve analysen
- 2) Markedsforhold
- 3) Aktivitet 30: Design System 2
- 4) Kompetencer & erfaringer
- 5) Aktivitet 10: Design

## Om analysen:

- **Analysegruppen**
  - 8 deltagere med i alt 56 års erfaringer
  - Lidt overvægt af røde profiler
- **Usikkerheder**
  - 42 nøgleord fordelt i 5 grupper (OF'ere)
- **Estimeringer**
  - Der blev estimeret: 15 aktiviteter og 5 OF'ere
  - I alt 480 estimater
- **Resultater**
  - Varighed af robusthed valgt
  - 5 handlingsplaner identificeret
  - Gennemført på den afsatte tid

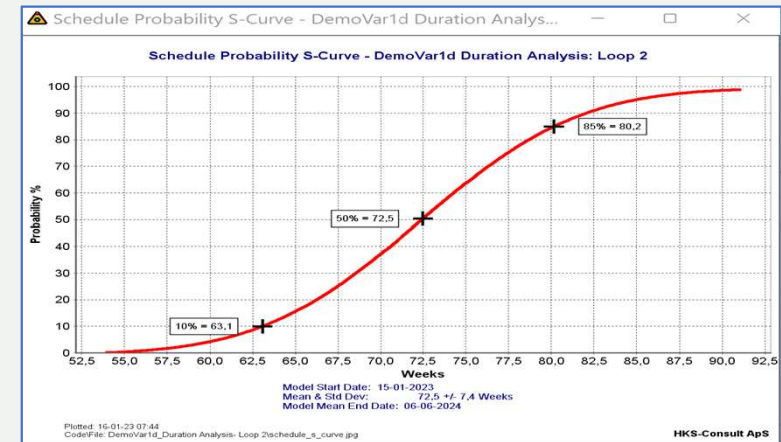

**Varighed: 73 uger +/- 7,5 uger**

## Handlingsplan

#	Handling	Bet. (1-3-5)	Hvem	Hvornår
1.	For yderlig 3-5 andre til at estimere	5	JPL	u05'23
2.	Lav yderlige markedsundersøgelser	3	HTH	u02'23
3.	Hyre en specialist in for design af System 2	5	EPJ	u03'23
4.	Find relevante uddannelser	5	HLS	u02'23
5.	Optimer processerne for Design System 1	3	POL	u06'23

# Fra Projektvarighed Til MS Project Plan

---

**Omsæt Usikkerhed - Til Robusthed**

---

# Fra varighed til plan

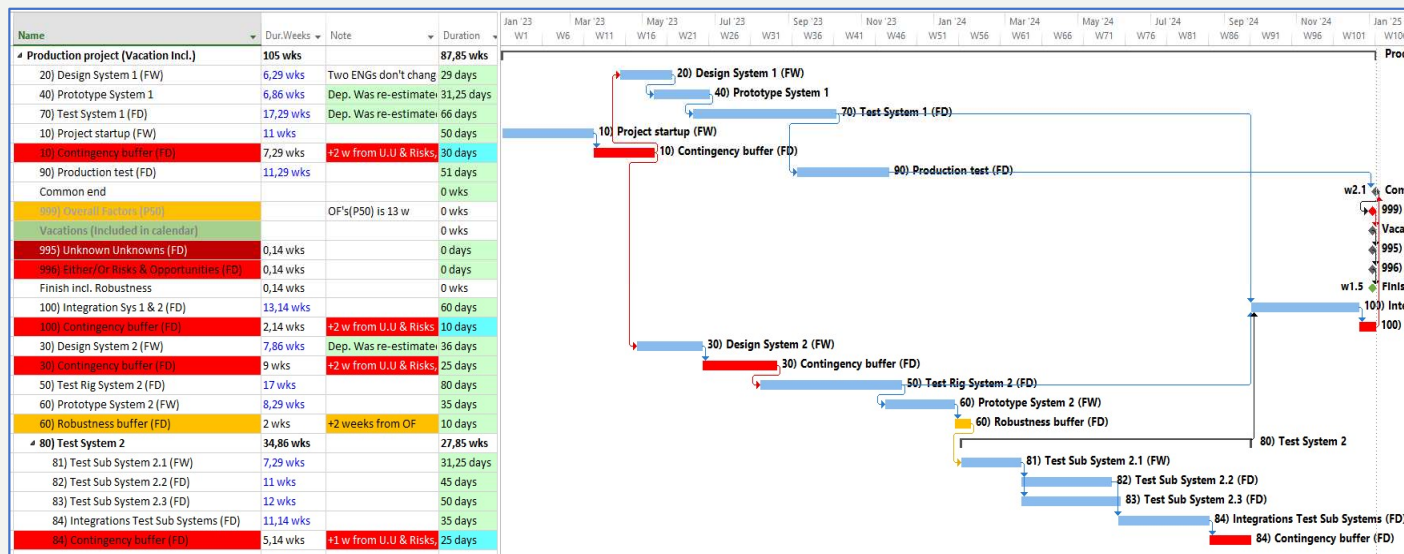
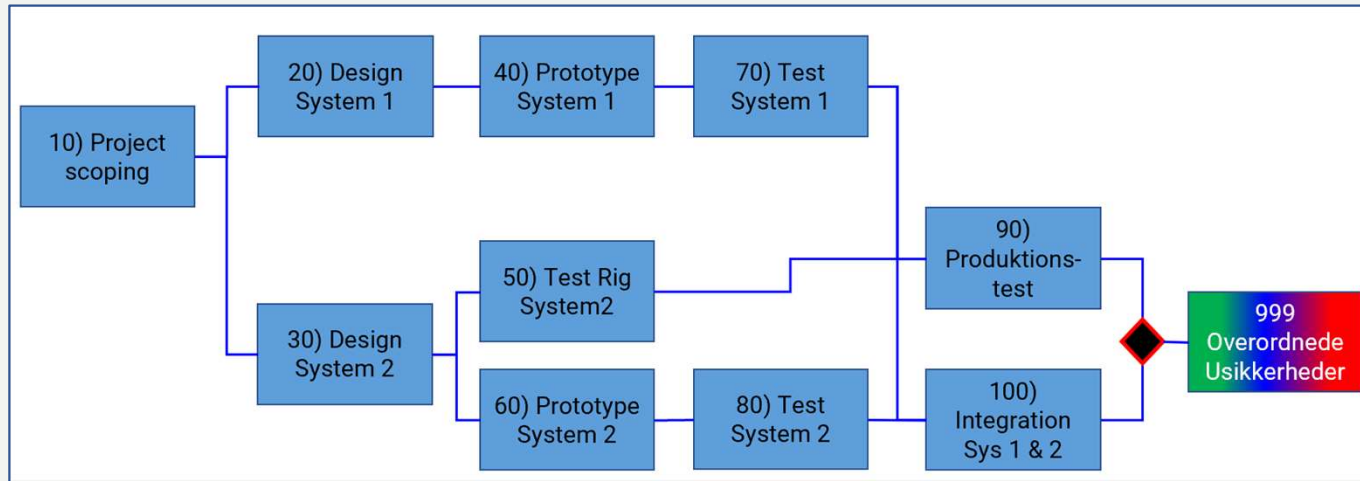

# Fra varighed til plan

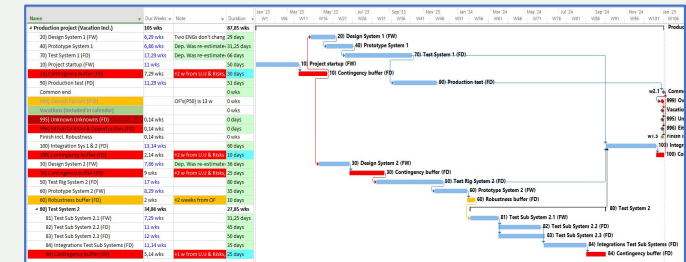
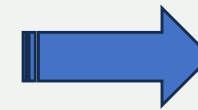
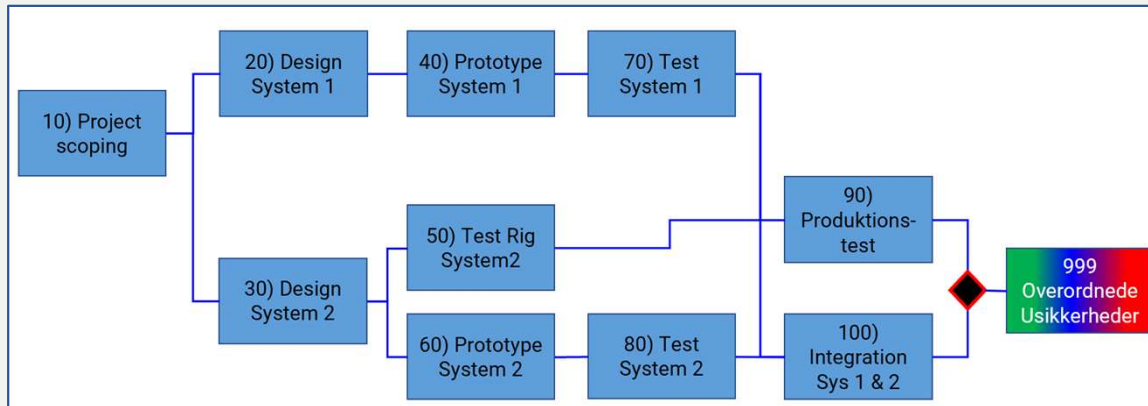

## Fremgangsmåde med fx MS Project (MSP)

1. Arbejdstid fx 37½ timer indstilles i MSP
2. Aktiviteternes varighed indtastes
3. Aktiviteternes afhængigheder indtastes
4. Aktiviteternes overlap (Slag/Lag) indtastes
5. Ferier lægges ind i MSP
6. Diskuter med projektgruppen, hvor buffere fra Generelle Usikkerheder skal lægges ind
7. Varighedsbufferen fordeles up-front i planen på de 3-5 mest usikre aktiviteter
8. Opdater buffere under udførelse:
  - i. Hvis de forbruges, så nedskriv den samlede buffer
  - ii. Hvis de ikke forbruges, så flyt dem fremad i planen
  - iii. Hvis en antaget usikkerheder ikke indtræffer, så nedskriv bufferen med denne del (frigiv ressourcer til andre projekter)



## SÅDAN SKABER VI VÆRDI



### ANALYSER

Vi udfører analyser af fx risici, omkostninger, tidsplaner, business cases og porteføljer m.v.



### PROJEKTLEDLESE

Vi udfører robust projektledelse med erfarne konsulenter i fx IT-, service-, udviklings-projekter.



### UNDERVISNING

Vi udfører undervisning i i fx analysemetoder, facilitering, & projektledelse.

Læs mere på [COMPILOT.dk](https://COMPILOT.dk)