

Appetizer

Tidlig Kvalitetssikring af Planer



Risk Management & Estimering i én proces. Mail@compilot.dk for slides



Hvad ønsker vi at opnå?

1. **At identificere og estimere usikkerheder** - for at kvalitetssikre projektet
2. **At identificere en vidde for projektets varighed** - for at vælge robusthed
3. **At få et fælles billede af projektet** - for at opnå ejerskab & motivation
4. **At lave handlingsplaner** - for at udnytte muligheder og reducere risici



Processen - Varighed

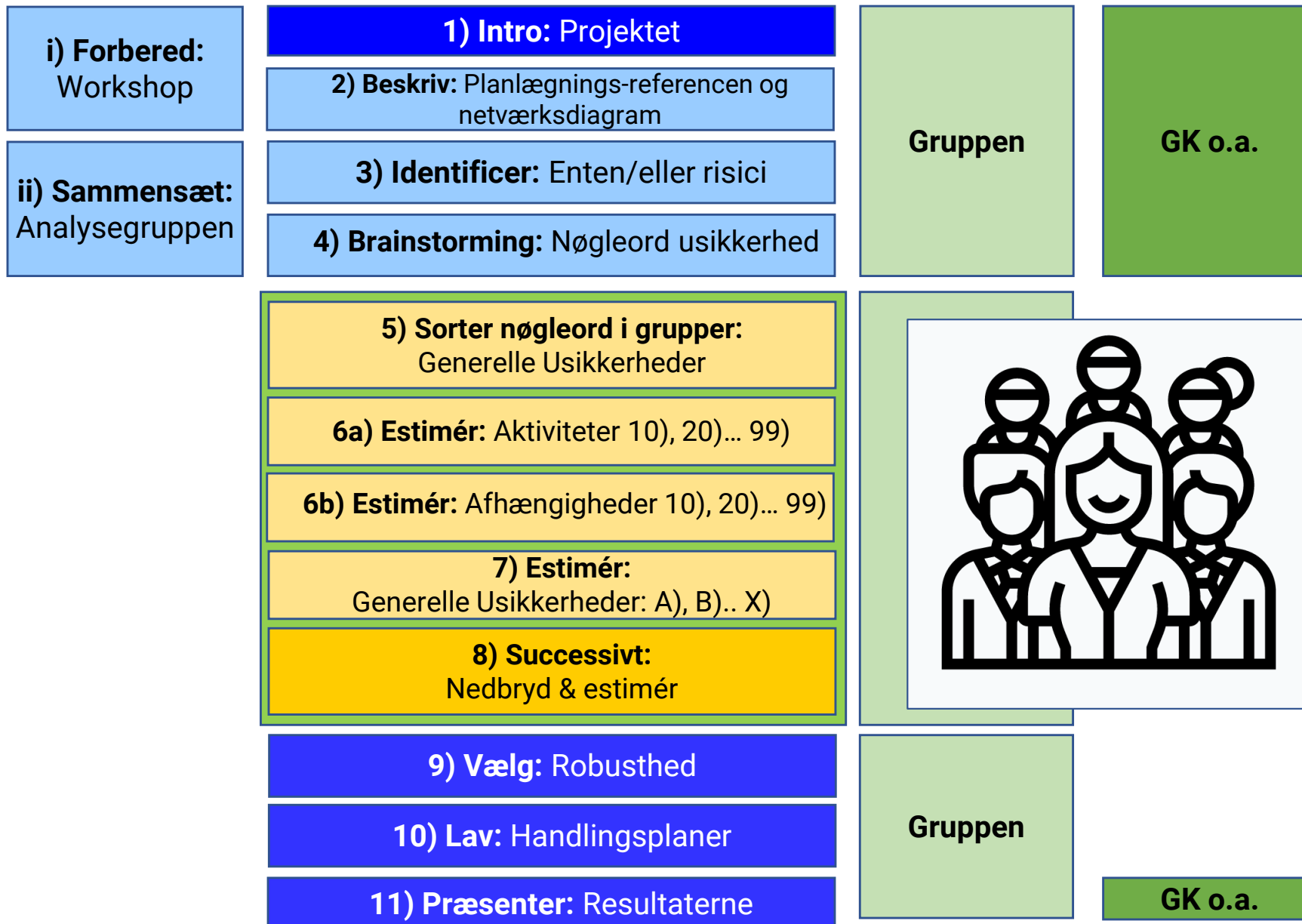

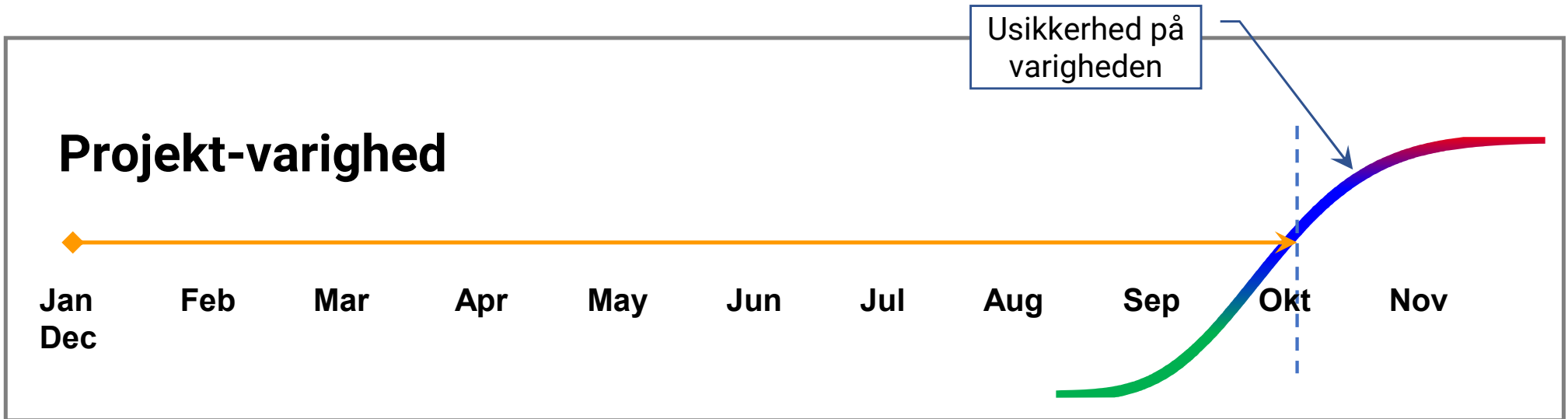

Handlingsplan

#	Handling	Bet. (1-3-5)	Hvem	Hvornår
1.	Sikre mandat i	5	HKS	u05'23
2.	Få sparring mht design	3	JKS	u02'23
3.	Definere kontraktstrategi	5	EPJ	u03'23
4.	Ansæt en Teambuilding leder	5	HLS	u02'23
5.	Involver 1-2 entreprenører i predesign	3	POL	u06'23
..				
..				
..				
xx.	Sikre en forsikringsplan	1		u10'23

Top10 usikkerheder

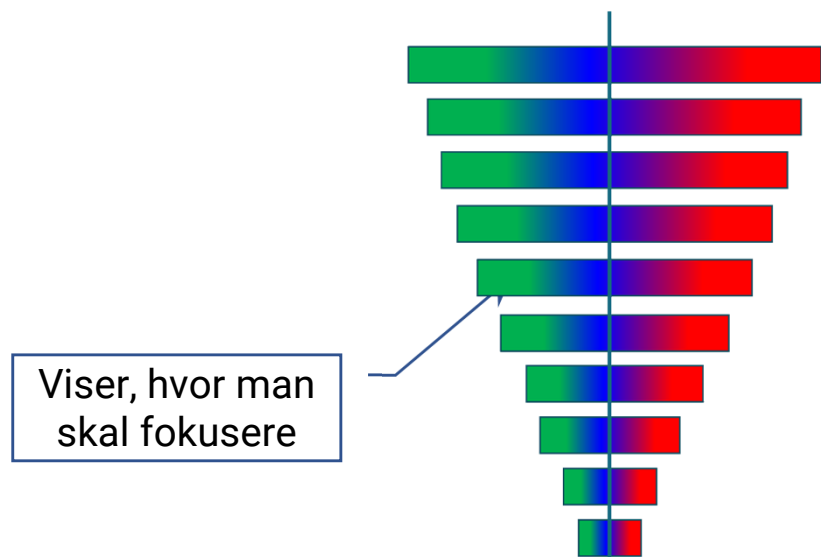



Development Project

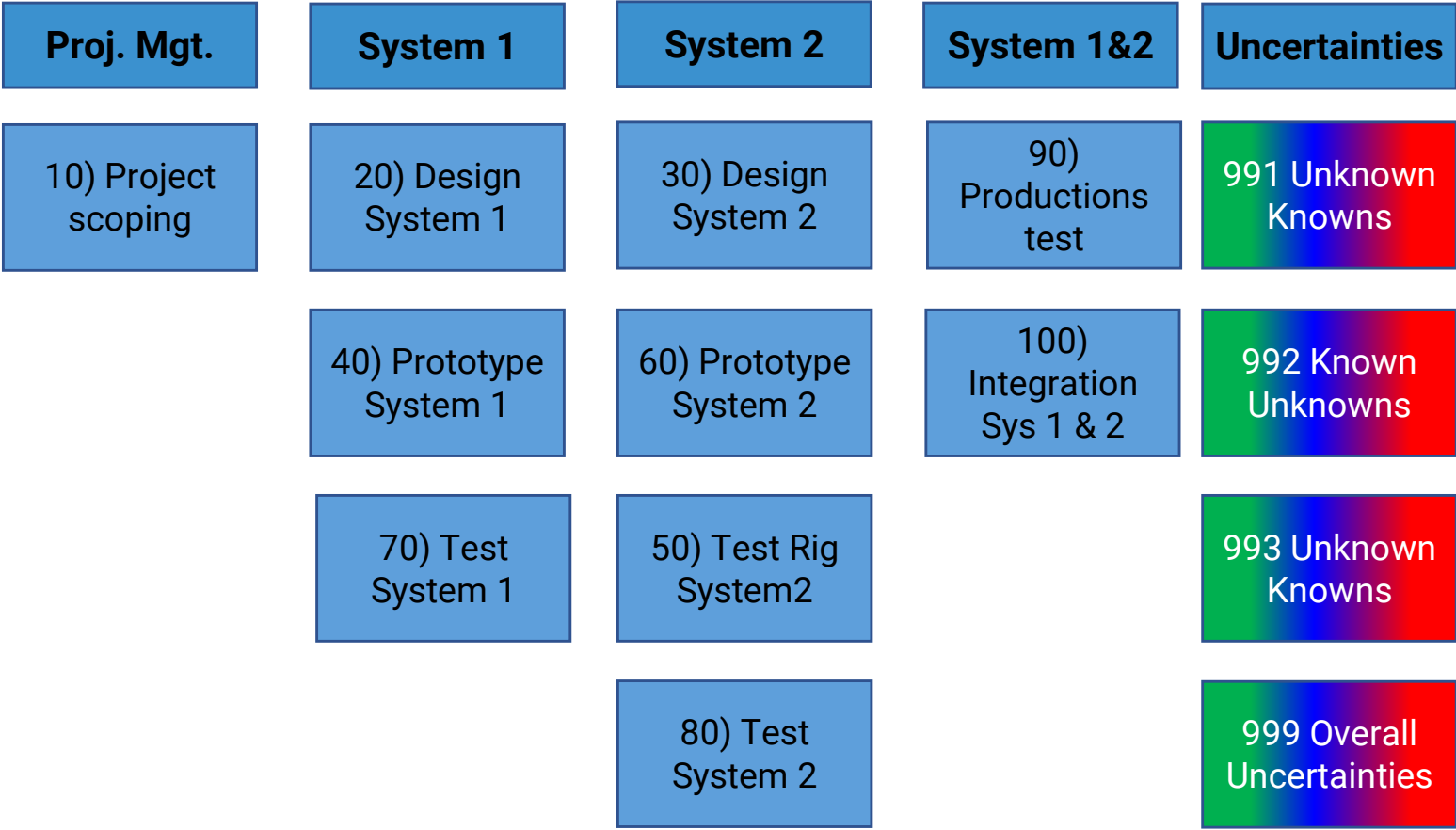

Estimering af varigheder



Loop 1a
Estimering af aktiviteter.

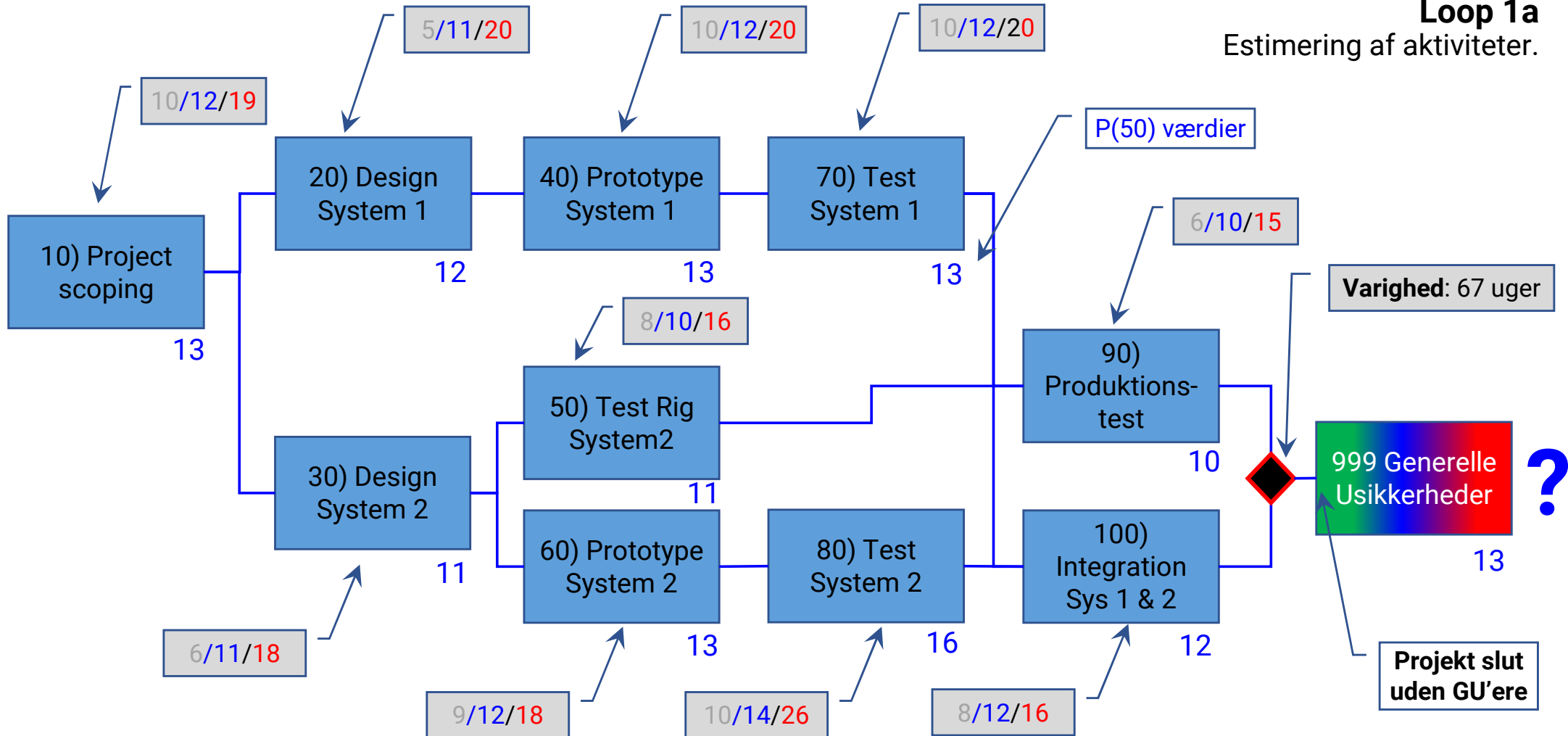



Kompression of varigheden

Loop 1b:
Estimering af afhængighederne.

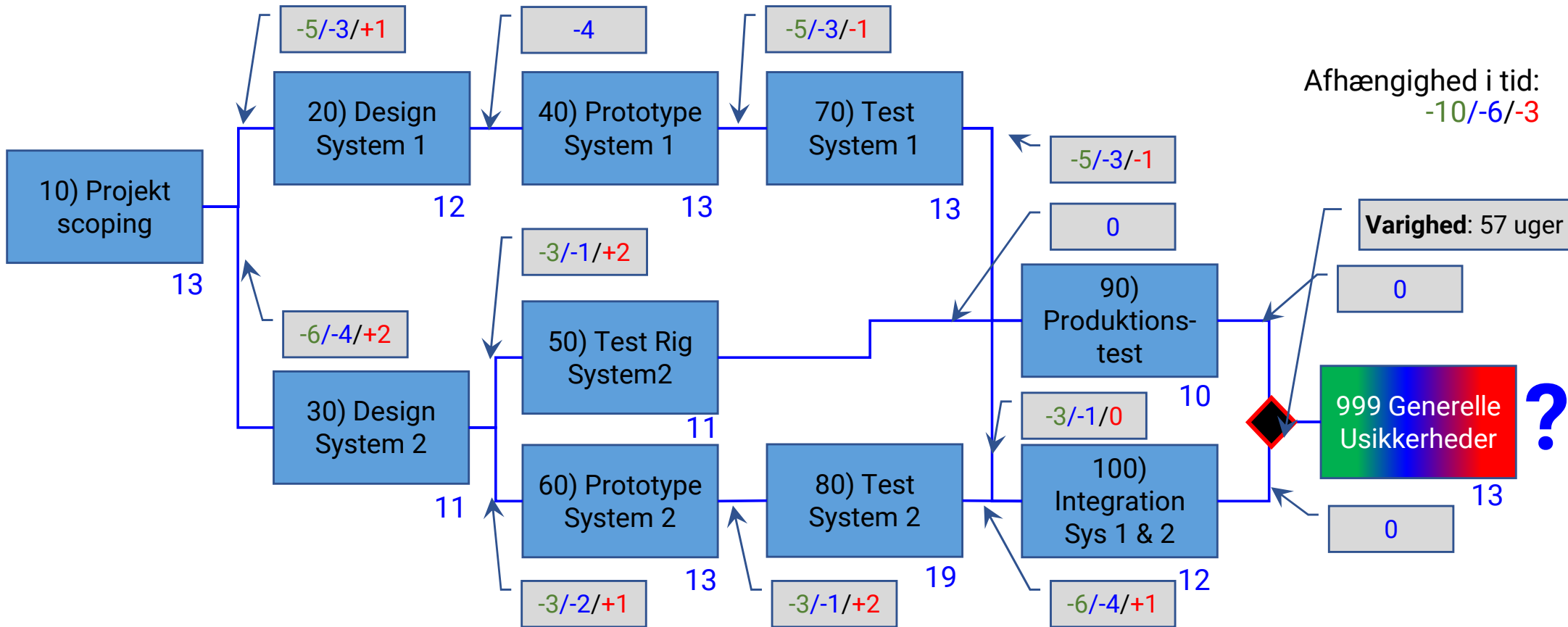

P(50) værdier uden OF'ere

Overlap (fremskyndelse) estimeres bagfra
Overlap: Tidlig start eller sen start



Projektvarighed Loop 2

Nedbrydning af Top1 aktiviteten



Loop 2
En kritisk aktivitet nedbrydes

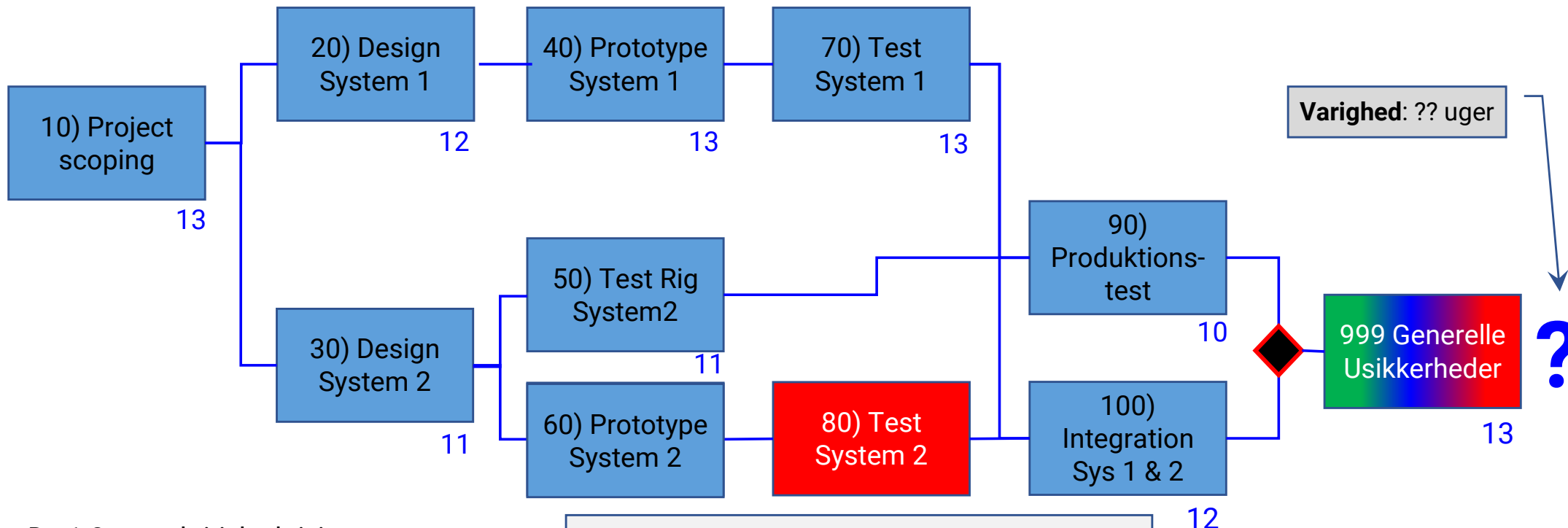

De 1-3 mest kritisk aktiviteter nedbrydes til næste niveau for at komme tættere på usikkerhederne.
(Her kun Top1)

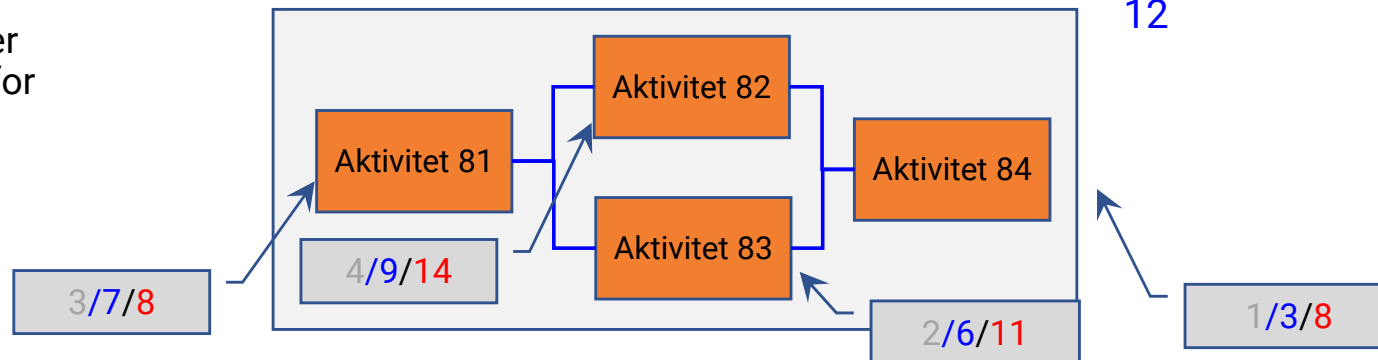

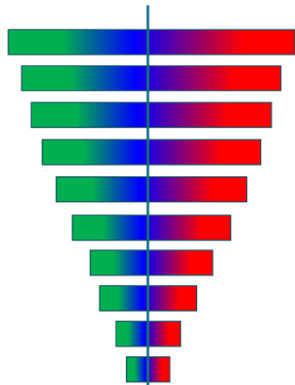

Top5 usikkerheder:

- 1) Usikkerheden af selve analysen
- 2) Markedsforhold
- 3) Aktivitet 30: Design System 2
- 4) Kompetencer & erfaringer
- 5) Aktivitet 10: Design

Om analysen:

- **Analysegruppen**
 - 8 deltagere med i alt 56 års erfaringer
 - Lidt overvægt af røde profiler
- **Usikkerheder**
 - 42 nøgleord fordelt i 5 grupper (OF'ere)
- **Estimeringer**
 - Der blev estimeret: 15 aktiviteter og 5 OF'ere
 - I alt 480 estimater
- **Resultater**
 - Varighed af robusthed valgt
 - 5 handlingsplaner identificeret
 - Gennemført på den afsatte tid

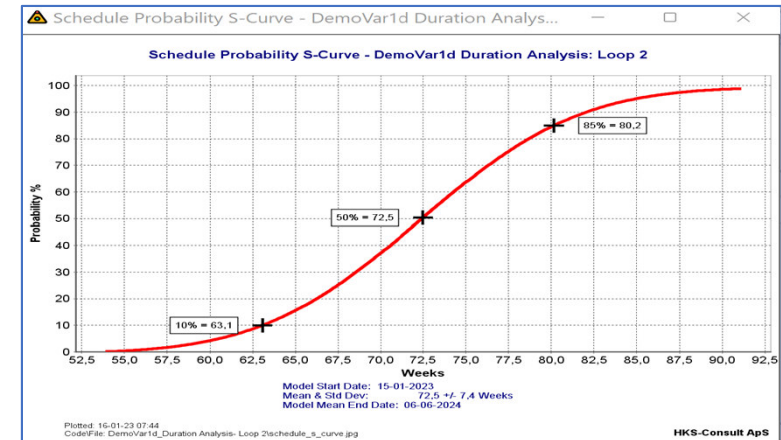

Varighed: 73 uger +/- 7,5 uger

Handlingsplan

#	Handling	Bet. (1-3-5)	Hvem	Hvornår
1.	For yderlig 3-5 andre til at estimere	5	JPL	u05'23
2.	Lav yderlige markedsundersøgelser	3	HTH	u02'23
3.	Hyre en specialist in for design af System 2	5	EPJ	u03'23
4.	Find relevante uddannelser	5	HLS	u02'23
5.	Optimer processerne for Design System 1	3	POL	u06'23

Fra Projektvarighed Til MS Project Plan

Omsæt Usikkerhed - Til Robusthed

Fra varighed til plan

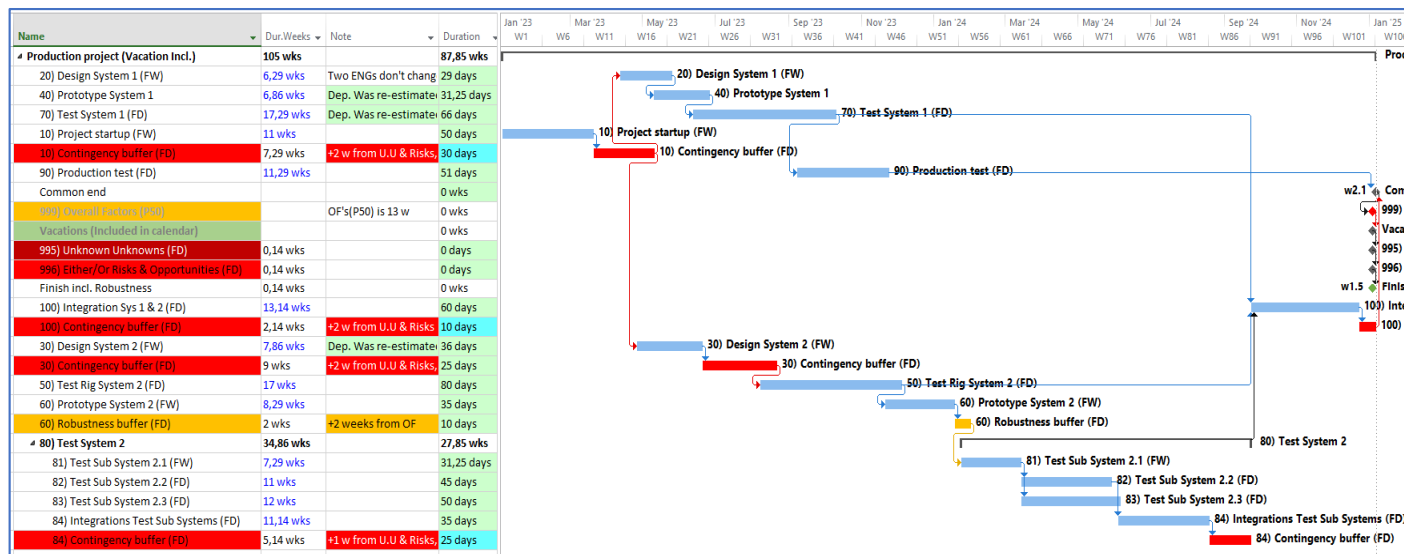
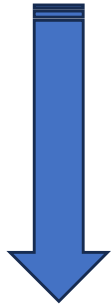
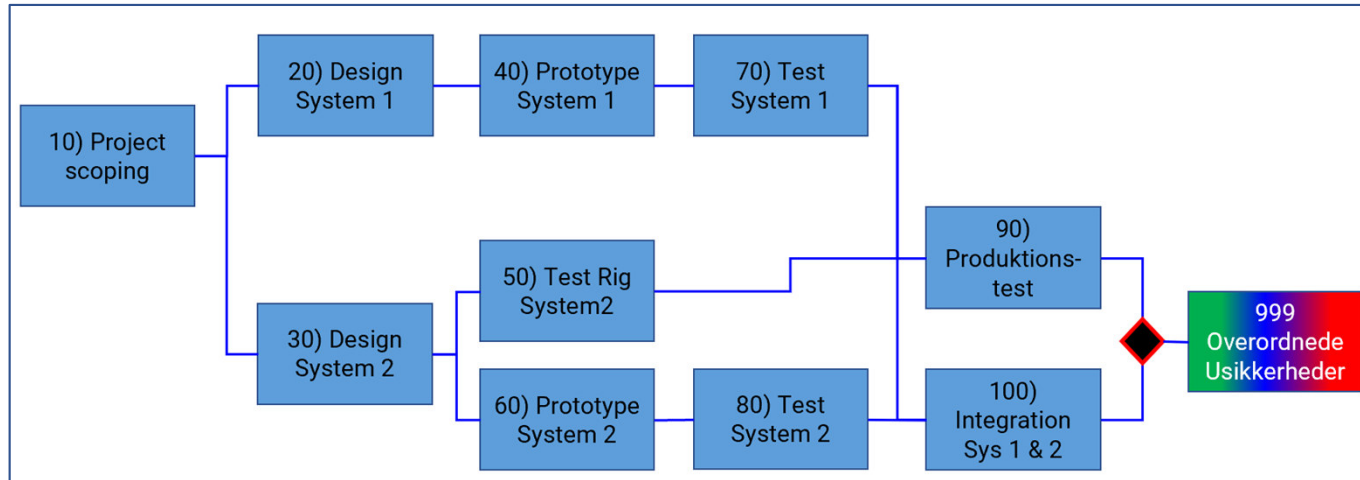

Fra varighed til plan

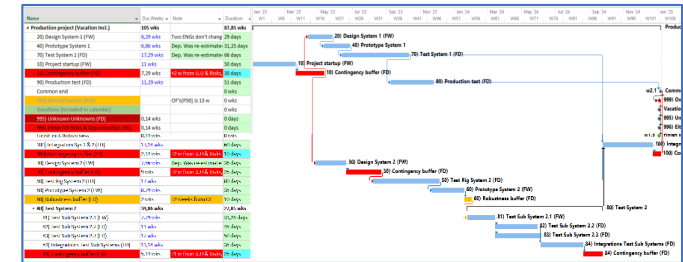
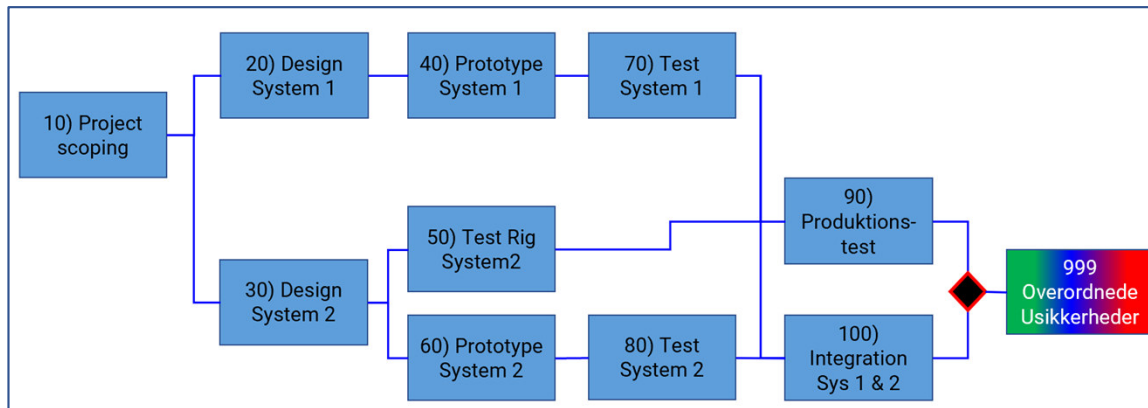

Fremgangsmåde med fx MS Project (MSP)

1. Arbejdstid fx 37½ timer indstilles i MSP
2. Aktiviteternes varighed indtastes
3. Aktiviteternes afhængigheder indtastes
4. Aktiviteternes overlap (Slag/Lag) indtastes
5. Ferier lægges ind i MSP
6. Diskuter med projektgruppen, hvor buffere fra Generelle Usikkerheder skal lægges ind
7. Varighedsbufferen fordeles up-front i planen på de 3-5 mest usikre aktiviteter
8. Opdater buffere under udførelse:
 - i. Hvis de forbruges, så nedskriv den samlede buffer
 - ii. Hvis de ikke forbruges, så flyt dem fremad i planen
 - iii. Hvis en antaget usikkerheder ikke indtræffer, så nedskriv bufferen med denne del (frigiv ressourcer til andre projekter)



PROJEKTLEDELSE BÆREDYGTIG PROCES & BUNDLINJE

SÅDAN SKABER VI VÆRDI



ANALYSER

Vi udfører analyser af fx risici, omkostninger, tidsplaner, business cases og porteføljer m.v.



PROJEKTLEDLESE

Vi udfører robust projektledelse med erfarne konsulenter i fx IT-, service-, udviklings-projekter.



UNDERVISNING

Vi udfører undervisning i i fx analysemetoder, facilitering, & projektledelse.

Læs mere på COMPILOT.dk